

Introduction

Inertia bases and vibration mountings are designed to reduce the transmission of noise and vibration from equipment to building structures and associated pipework. When installed with rubber bellows or stainless steel hose & pump connectors they provide an ideal vibration and noise isolation solution. Inertia bases are designed to support reciprocating equipment such as pumps, chillers, generators and air handling equipment. The inertia base is manufactured from a fully welded carbon steel zinc frame fitted with vibration mounts. The inertia base are specifically designed and engineered to receive poured concrete which can be supplied empty, pre-filled with concrete or pre-filled with Pumps fitted. It is by adding this mass and by lowering equipment centre of gravity it is installed under that enables the inertia base to provide a stable support. This is particularly important for equipment which exhibits high out-of-balance forces and are top-heavy such as pumps. The concrete base enables a reduction in motion from pump start up and minimises the effect of unequal load distribution. Inertia bases are not only manufactured to suit the equipment for which it's designed to support but can also be sized to suit site conditions. This is particularly advantageous in tight restrictive areas such as building services plant rooms. All Bases are supplied with Anti-Vibration Mounts designed to support the combined load of Pump, Concrete Base and Water and retain a 50% overcapacity. When installing rubber bellows to a pump that is supported by inertia base the rubber bellows should be supplied with tie bars. Tied units are designed to stop the bellows from elongating and prevent the pressure thrust being transmitted on to the pumps and associated pipework. Easyflex rubber flexible connectors are supplied with threaded tie rods whose primary function is to maintain the supplied length of the rubber bellows under pressure while permitting only lateral deflection.



Easyflex Inertia Base come in several standard sizes as listed in our catalogue. However, these bases can also be manufactured to any size and specifications, even for heavier and more complex vibration isolation problems, where viscous damping may also be required. For frame lengths greater than 2400 mm we would normally recommend 6 isolators or more for exceptionally large bases.

Examples of equipment requiring Inertia Base are as follows:

- Reciprocating Compressors
- Diesel Generating Sets
- Engine / Dynamometer Test Rigs
- Refrigeration Plants
- Pumps (Particularly Belt Driven Types)

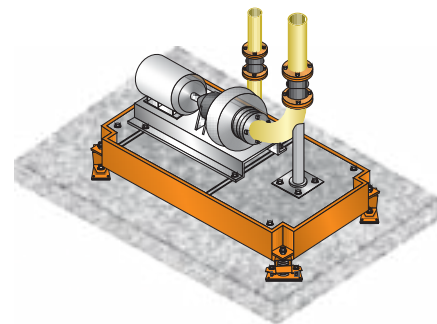

Features

- Fully welded steel construction with integral concrete reinforcement fixed at 40 mm above bottom of frame.
- Recessed height reducing corner brackets designed to accept standard Easyflex type EFOS open spring mountings or EFESI Mounts.
- Range of standard size frames available in three thicknesses 150, 200, 300 & 350 mm. Frame thickness not less than $L/12$ where "L" is the longest side of the frame as per ASHRAE.
- Finished with a single coat of red oxide primer on external surface only.
- Fabricated using formed steel channel (EFIB). Optionally available in structural steel channel construction.
- Available for any equipment dimension. Rectangular shape supplied as standard. T-shape offered where it is required to support elbows of horizontal split casing pumps on the base itself.
- Reinforced with 12mm OD welded-in steel rebar each way, at approximately 150mm spacing.
- Provided with height saving isolator fixing brackets. External brackets are supplied as standard. Recessed brackets are offered in case of space constraints.
- Supplied together with Easyflex isolator, Selection of mount type/models forms part of the EFIB design process, to provide a complete vibration isolation solution. Frames are compatible with Open, Cased and Restrained mounts.

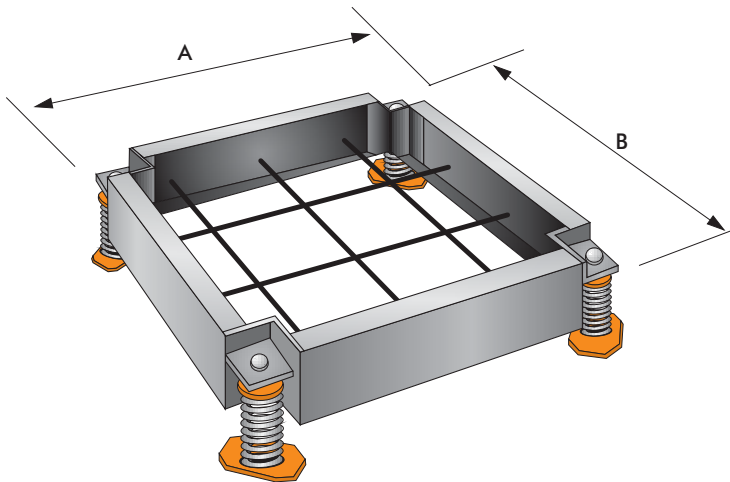

Notes

Frame weights include concrete density at 2400 Kg/m³ and mounting selections are based on 4 mountings per base allowing 50% additional weight for the equipment to be supported. Nominal 25 mm deflection type EFOS (Open Spring Isolators) have been listed, however the exact deflection will vary depending on the applied load.

When ordering, bases should be specified as follows: EFIB 150 - 600 x 900 Other Size. Type and Thickness required and plan dimensions commencing with smallest length. Mountings should also be listed e.g. "EFOS25/100-BLUE"

Important

The equipment should be located on the base such that the load is evenly distributed over the 4 mountings.

Equipment and ancillary parts should not overhang frame and hold down bolts must not be at a distance less than 100 mm from the outer edge of the base.

All the connections to the equipment should incorporate flexible sections and pipework etc. must be independently supported.

Concrete Plinth if any, should be at least 200mm more than the size of base in all directions. In case of installation of snubbers it should be increased to 300mm.

Compliance - Easyflex Inertia Bases are designed according to ASHRAE guidelines.

Ordering Information Required

- Equipment Model / Make
- HP / RPM of Motor
- Static Weight of equipment
- Operating / Dynamic weight of equipment
- Outside Dimensions L x B x H
- Concrete Plinth Y/N
- Height / Space Constraint if any
- Required Deflection of Spring (25mm / 50mm)
- Location - Ground | Roof | Basement

Standard Base Sizes & Mounting Selection

FRAME SIZE A X B (mm)	150mm THICK		200mm THICK		300mm THICK	
	WT(Kg)	MOUNT PART NO.	WT(Kg)	MOUNT PART NO.	WT(Kg)	MOUNT PART NO.
600 x 600	147	EFOS25/60 Green				
600 x 750	180	EFOS25/100 Blue				
600 x 900	211	EFOS25/100 Blue				
600 x 1200	277	EFOS25/160 White				
600 x 1500	341	EFOS25/160 White				
750 x 750	219	EFOS25/100 Blue	288	EFOS25/160 White		
750 x 900	259	EFOS25/100 Blue	342	EFOS25/160 White		
750 x 1200	339	EFOS25/160 White	448	EFOS25/250 Red		
750 x 1500	420	EFOS25/160 White	554	EFOS25/250 Red		
750 x 1800	500	EFOS25/250 Red	660	EFOS25/300 Purple		
900 x 900	307	EFOS25/160 White	404	EFOS25/160 White	600	EFOS25/300 Purple
900 x 1200	402	EFOS25/160 White	531	EFOS25/250 Red	788	EFOS25/300 Purple
900 x 1500	498	EFOS25/250 Red	658	EFOS25/300 Purple	977	EFOS25/400 Grey
900 x 1800	594	EFOS25/250 Red	785	EFOS25/300 Purple	1166	EFOS25/500 Orange
900 x 2100			911	EFOS25/400 Grey	1353	EFOS25/500 Orange
1050 x 1050	465	EFOS25/250 Red	542	EFOS25/250 Red	804	EFOS25/300 Purple
1500 x 1500	575	EFOS25/250 Red	761	EFOS25/300 Purple	1121	EFOS25/500 Orange
1050 x 1800	687	EFOS25/300 Purple	908	EFOS25/400 Grey	1350	EFOS25/500 Orange
1050 x 2100			1055	EFOS25/400 Grey	1570	EFOS25/600 Brown
1050 x 2400			1201	EFOS25/500 Orange	1788	EFOS25/800 Green
1200 x 1200			699	EFOS25/300 Purple	1038	EFOS25/40 Grey
1200 x 1500			865	EFOS25/400 Grey	1286	EFOS25/50 Orange
1200 x 1800			1032	EFOS25/400 Grey	1536	EFOS25/60 Brown
1200 x 2100			1199	EFOS25/500 Orange	1785	EFOS25/80 Green
1200 x 2400			1369	EFOS25/600 Brown	2038	EFOS25/80 Green
1400 x 1400					1397	EFOS25/600 Brown
1400 x 1800					1783	EFOS25/800 Green
1400 x 2100					12074	EFOS25/800 Green

- Due to policy of continual improvement, the specifications are subject to change without prior notice.
- Measurements are subject to 5% tolerance.
- To achieve good results do not over load fitting more than designed parameters as per drawing / catalogue.