

Type 1055

This unique solution enables solid plate flooring to be fitted to open-mesh or open-grid flooring using simple hand tools.

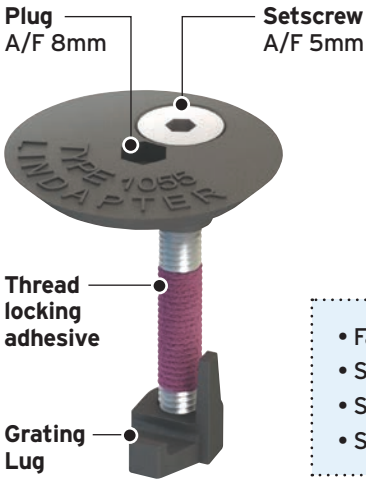

- Fast installation from above, no need for expensive scaffolding.
- Stainless steel for high corrosion resistance.
- Superior clamping force from high quality castings.
- Safely retrofit without welding, no need for hot work permits.

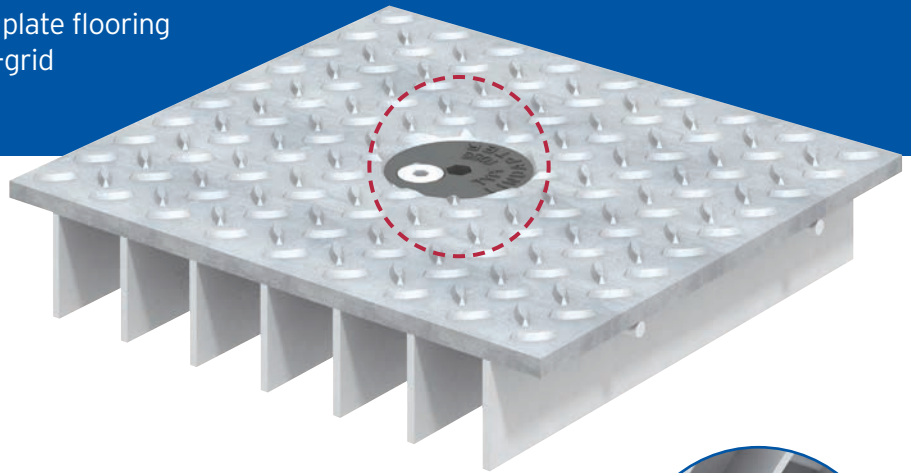
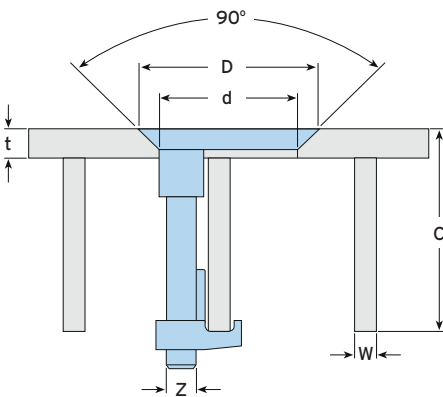
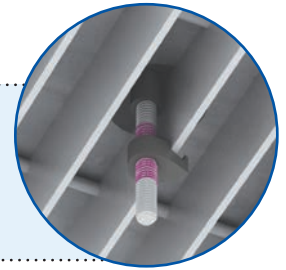

Material: Cast stainless steel, self colour.



Product Code	Bolt A4-70 Z	Floorplate Thickness t mm	Clamping Range C mm	Grating Bar Width W mm	Hole Ø d mm	Counter-sunk Ø D mm	Setscrew	
							Tightening Torque Nm	Hexagon Key mm
FG1055	M8	min. 6	35 - 56	3 - 8	40	50	11	5

- Safe Working Loads (FG1055): Tensile = 1kN/bolt (4:1 FoS) Slip = 0.15kN/4 bolts (4:1 FoS)
- Designed for pedestrian walkways only.

How to install...

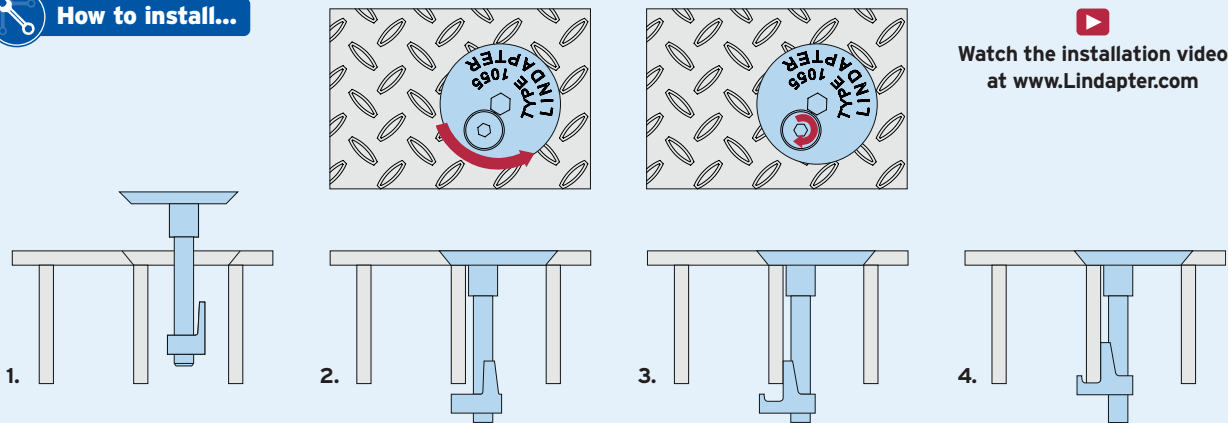

Watch the installation video at www.Lindapter.com

- 1) Insert the pre-assembled Type 1055 into the countersunk hole between the grating bars.
- 2) Use an 8mm hexagon key to rotate the plug anti-clockwise until the underside of the plug locates against the grating bar.
- 3) Use a 5mm hexagon key to rotate the countersunk setscrew clockwise until the grating lug makes contact with the grating bar.
- 4) Tighten the setscrew to 11Nm; the grating lug will be drawn up the screw and will activate the thread locking adhesive.

For Characteristic Resistances when designing a connection to Eurocode 3, refer to DoP No.015 on Lindapter's website or request the DoP Brochure >>

